

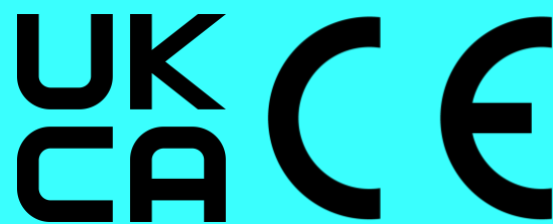

EMOVELIFT

Operating Manual

February 2023





Proprietary information

This operating manual has been prepared by GO LEAN Ltd. for internal use and approved release to external parties. The document contains confidential information relating to GO LEAN products, designs and technical know-how, and shall not be duplicated or distributed without express permission.

For electrical information, refer to the “installation instructions for electrical drive system EM 2000”, which was supplied as hard copy with the product.

Disclaimer

This manual is a guide to the operation

GO LEAN Ltd shall not under any circumstances accept any liability arising from any use of out of date information.

Revision History

Revision	Date	Reason
A	03/02/2023	First Issue



1 Declaration of Conformity

Manufacturer:

GO LEAN Ltd
128 City Road
London
EC1V 2NX
United Kingdom

Product Range: LEAN MOVE

Model: EMOVELIFT 1.25K

Serial Number: EML-0015-1

Safe Working Load: 1,250kg

GO LEAN hereby certifies this product conforms to the machinery equipment directive, CE, UKCA the relevant British standards and has been manufactured to GO LEAN quality procedures, to ensure safety and customer satisfaction.

This product was proof tested by an independent testing provider and LEEA member, at 1.25 times the safe working load at 500mm load centres.

Proof test certificate number: P14994

Applicable Standards:

BS EN 1757 Safety of industrial trucks. Pedestrian propelled industrial platform trucks

Date: 3th February 2023

Certified on behalf of: GO LEAN Ltd

Job Title: Chief Executive Officer

Name: Oliver Buhlinger



Introduction

Thank you for choosing LEAN MOVE. To gain the intended benefits and safe operation, please read the instructions carefully before operation. We recommend carrying out the appropriate safety assessments and training of the operators before integrating EMOVELIFT into your processes, where applicable.

Printed forms of this document or static versions could be out of date, GO LEAN reserves the right to update and improve its products, it is recommended to always check for the latest version on the website or customer portal, or contact info@igo-lean.com.



Contents

Proprietary information ii

Revision History ii

1 Declaration of Conformity iii

Introduction iv

Contents..... v

List of Figures..... vii

Specifications 8

2 Overview 9

 2.1 Safe Working Load 9

 2.2 Emovelift Controls 10

 2.3 Emovelift Hydraulic Hand Pump 11

3 Operation 12

 3.1 Switching the EMOVELIFT off 12

 3.2 Switching the EMOVELIFT on 12

 3.3 The Anti-Trap Protection 12

 3.4 Charging 12

 3.5 Warning signals 12

 3.6 Lifting the Load 12

 3.7 Lowering the Load 13

 3.8 Refilling Hydraulic Hand Pump Oil 13

 The steel tank 13

 3.9 Movement 13

 Operating the Controls 13

4 Safety 14

 4.1 Operator Safety 14

 Training 14

 Personal Protective Equipment (PPE) 14



5	Applicable Legislations and Regulations.....	15
	Bill of materials.....	16
	Appendix A – Hydraulic Oil Specification	17
	Appendix B – General Arrangement	18
	Glossary of Terms.....	19



List of Figures

Figure 1: Safe working load and force diagram	9
Figure 2: Load centre distance (mm) vs safe working load SWL (kg)	9
Figure 3: Emovelift controls	10
Figure 4: Hydraulic hand pump components	11



Specifications

Item	Specification
Capacity (kg)	1,250 at 500 mm load centres
Weight NET (kg)	280
Length (mm)	1566
Width (mm)	1152
Height (mm)	1071
Stroke (mm)	200
Voltage (V)	48
Charger Voltage (V)	220-240

2 Overview

2.1 Safe Working Load

SWL 1,250kg at 500mm load centres

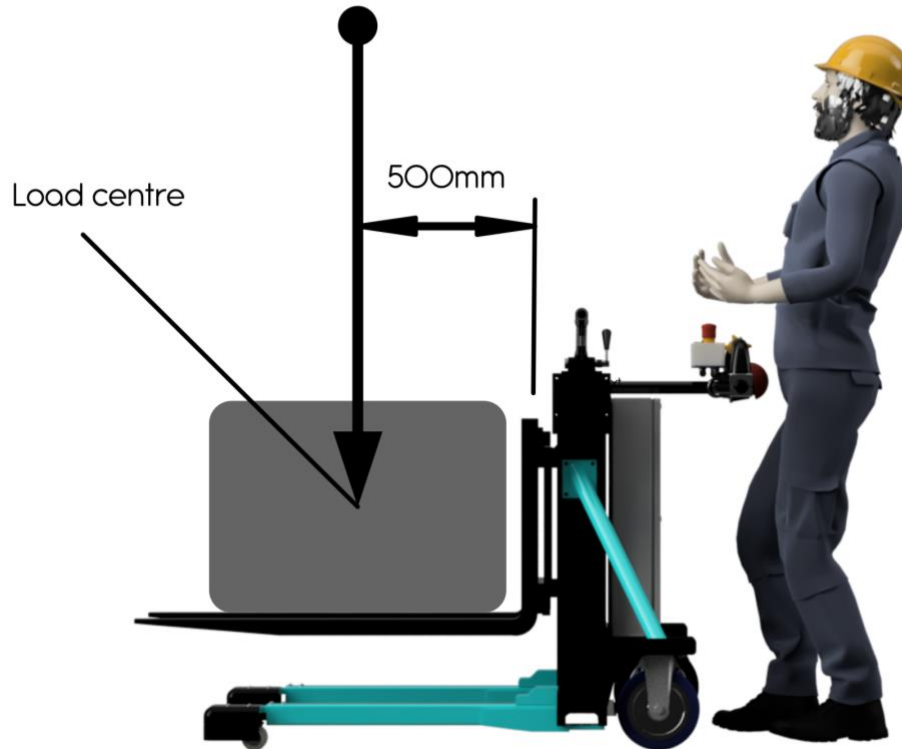

Figure 1: Safe working load and force diagram

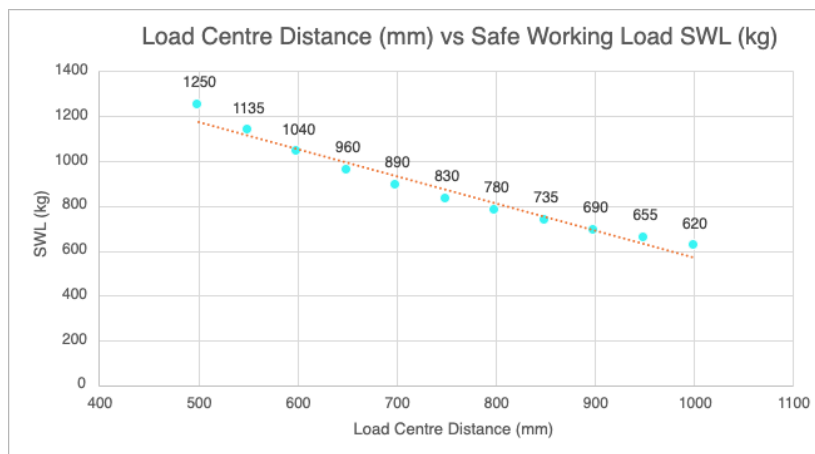

Figure 2: Load centre distance (mm) vs safe working load SWL (kg)

2.2 Emovelift Controls

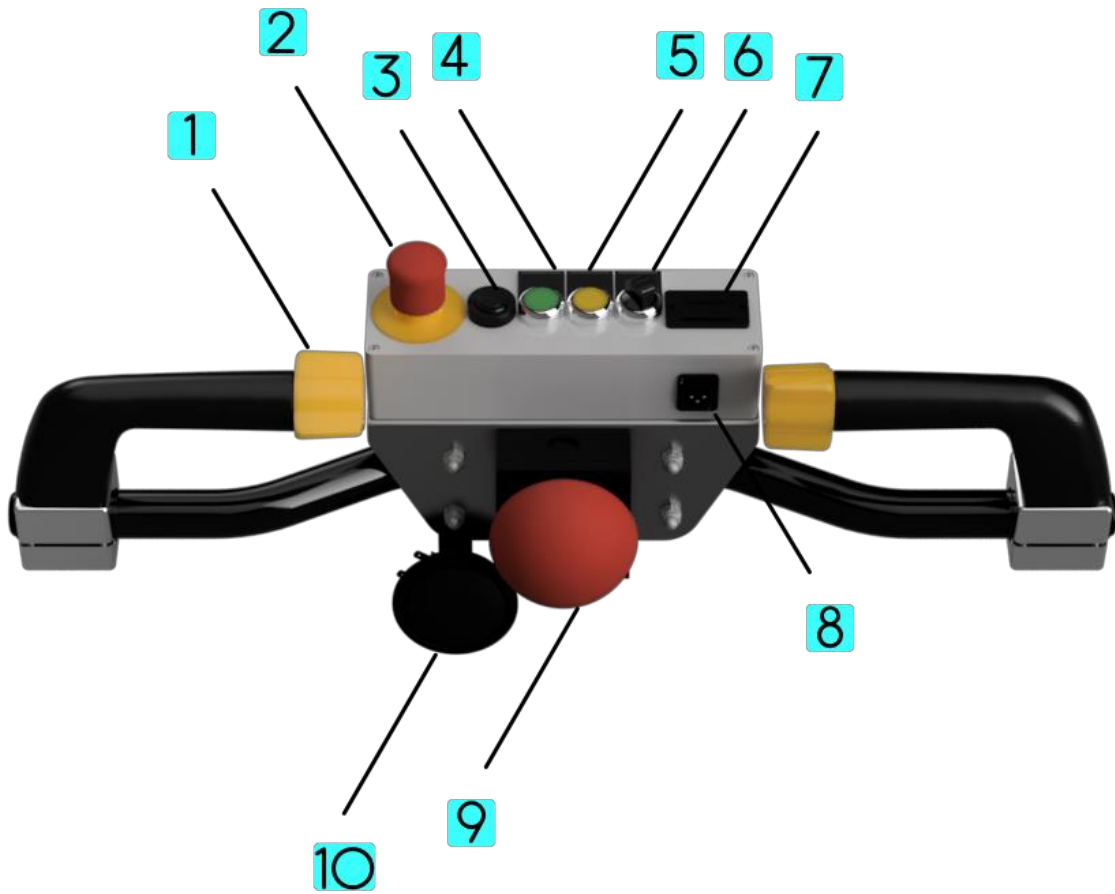

Figure 3: Emovelift controls

1	Rotary joystick & hand detection	6	Mode “I” and “II” switch
2	Emergency stop button	7	Charge level display
3	Key switch	8	Charging unit port
4	On button	9	Anti-trap protection
5	Horn button	10	Warning horn

2.3 Emovelift Hydraulic Hand Pump

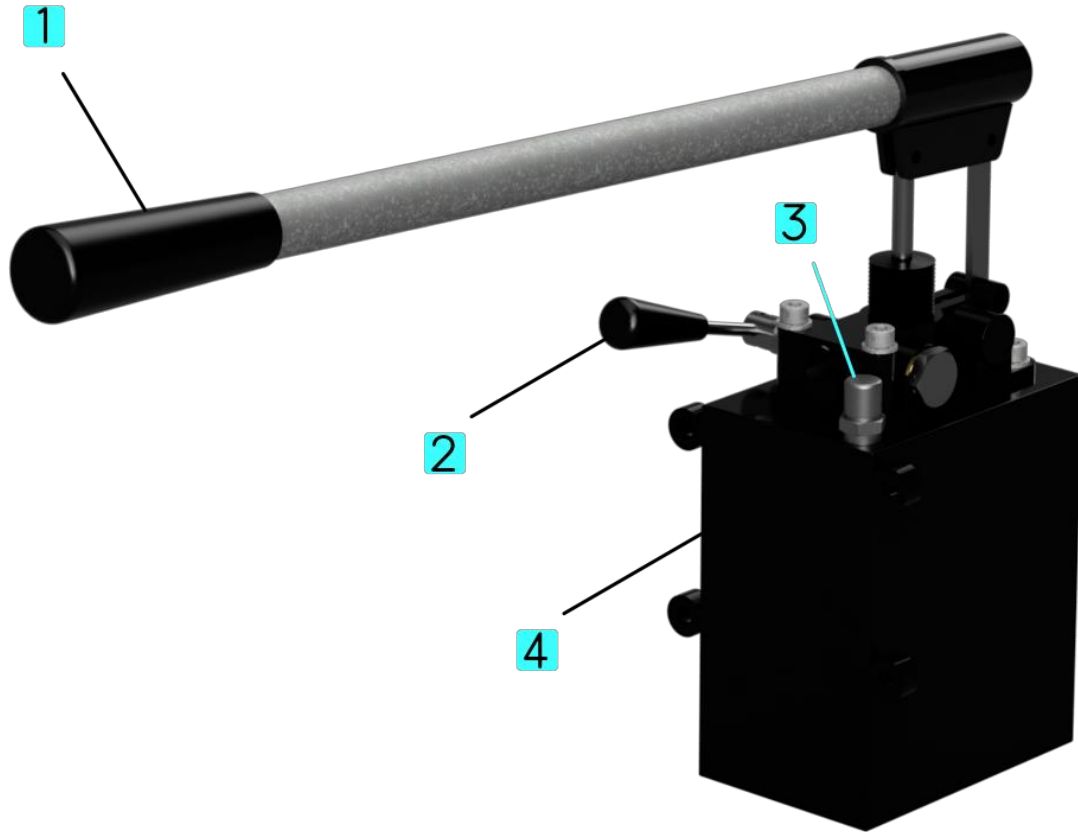

Figure 4: Hydraulic hand pump components

1	Pump lever
2	Release lever
3	Filling port and breather cap
4	Steel oil tank

3 Operation

3.1 Switching the EMOVELIFT off

Switch off by turning the key into the off position. Remove the key and lower any load to the ground.

3.2 Switching the EMOVELIFT on

3.3 The Anti-Trap Protection

The anti-trap protection on the Emovelift is implemented with a pressure-sensitive mushroom button. If the button is pressed against the operator, the trolley will quickly move back in the opposite direction of travel to avoid potential crushing injuries.

3.4 Charging

To charge the Emovelift, switch the Emovelift off. Use the supplied charger and plug the charger mains plug into a socket first. Plug the male XLR plug into the female socket on the cockpit

Control box / battery

The control box contains the battery and control unit of the Emovelift and controls the driven wheels and the cockpit. The Emovelift is equipped with state-of-the-art rechargeable battery technology. At full capacity, the battery can make up to 500 starts with a load of 2,000 kg. The charge time is approximately four hours (90 percent of capacity).

3.5 Warning signals

Use the horn to alert pedestrians and oncoming vehicles of your presence. Using the horn just before approaching a corner can help alert pedestrians and vehicles that might be around a corner but not yet visible to you.

3.6 Lifting the Load

Before commencement of a lifting operation, check the weight of the load. Please refer to Figure 1: Safe working load and force diagram.

Note:

The load capacity decreases, the further away the load centre is from the pivot point (mating surface between fork and carriage).

Place the hydraulic locking lever into the locked position, clockwise rotation for locking, anti-clockwise for unlocking. Operate the hand pump lever in an down/up motion to raise the load to the required position.

3.7 Lowering the Load

Lower the load by releasing the locking lever slowly in an anti-clockwise rotation. Ensure the area below the load is clear from anything that could be trapped or crushed.

3.8 Refilling Hydraulic Hand Pump Oil

Before refilling any oil, ensure to lower the forks completely to ensure the oil returns to the tank, to avoid overfilling the tank. To fill, remove the breather cap on the top of the steel tank and use the supplied funnel. Pour the ISO 32 oil from the supplied container into the funnel, regularly checking for the oil level, until approximately 75% of the tank volume.

3.9 Movement

Before moving, always ensure the load is clear from the floor to prevent dragging, floor damage and waste of energy through unnecessary friction, unless operating in load transfer where the load has castors, in this case, ensure that sufficient load transfer is in place to ensure the load will move with the Emovelift.

Operating the Controls

The Emovelift is operated with a set of rotary joysticks. The operation of the rotary joysticks determines the drive torque of the two driven fixed castors. Depending on the mode, the two castors are controlled synchronously or individually. The operating handles also feature integrated sensor-based hand detection for unlocking the electro-mechanical dead man's brake.

Mode I:

Both motors are controlled together

(forward 4 km/h, reverse 2 km/h).

Mode II:

Motors are controlled individually by

the respective rotary joystick (forward, reverse 2 km/h).

4 Safety

4.1 Operator Safety

Training

Please ensure that operators are suitably qualified and experienced before commencing operation of the Emovelift.

Equipment Safety Assessments

It is your responsibility as an organisation to comply with applicable safety standards and regulations. It is recommended to put in place relevant processes and procedures to ensure the Emovelift is regularly assessed for the following but not an exhaustive list.

- Any damage
- Torque of the fasteners
- Oil levels and leakages
- Fractures in the load bearing components
- Castor condition
- Operational warning horn
- Electrical cable and cable glands conditions
- Fork condition
- Hydraulic cylinder condition
- Drive wheel conditions
- Emovelift controls and rigidity of the handle bar
- Foreign object debris preventing the Emovelift from operating safely

Personal Protective Equipment (PPE)

It is recommended to use the following personal protective equipment:

Operation of the Emovelift

It is recommended to use protective footwear to prevent injury to the lower limbs.

Servicing and inspection of the Emovelift

- It is recommended to use protective gloves when servicing and inspecting the Emovelift to avoid injury to hands.
- It is recommended to wear eye protection when inspecting or servicing the Emovelift.

5 Applicable Legislations and Regulations

Some of the standards listed here are applicable to the manufacturer only, whilst some are applicable to the end user / employer purchasing the equipment to use in their processes.

- Health and Safety Work Act 1974
- The Management of Health and Safety at Work Regulations 2006
- Workplace (Health, Safety and Welfare) Regulations 1992
- Provision and Use of Work Equipment Regulations (PUWER) 1998
- Lifting Operations and Lifting Equipment Regulations (LOLER) 1998
- The Reportable Injuries Diseases & Dangerous Occurrence Regulations 2013 (RIDDOR)
- Control of Substances Hazardous to Health Regulations 2002
- The Work at Height Regulations 2005
- The Personal Protective Equipment at Work Regulations 2002
- The Manual Handling Operations Regulations 1992
- Electricity at Work Regulations 1989
- The Pressure Systems Safety Regulations 2000
- Pressure Equipment Regulations 1999 (SI 1999/2001)
- The Environmental Protection Act 1990
- Ozone Depleting Substances Regulation (EC) 2037/2000
- The Hazardous Waste Regulations 2005

Bill of materials

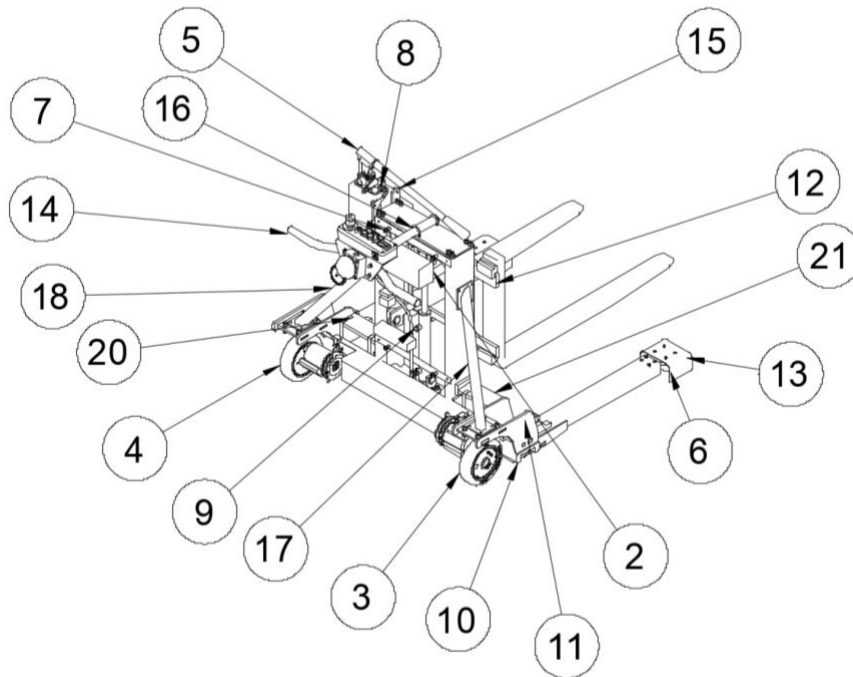

Item	Qty	Part Number	Description
2	1	EML_920662_CTRL	Control Panel
3	1	EML_920572	Drive Wheel Right
4	1	EML_920571	Drive Wheel Left
5	1	HPTCV_12_SR02FE_LV27X600	Hydraulic Hand Pump
6	2	LHD-GSPO_60K_754586-214	Swivel Castor 60 mm Diameter
7	4	M8x30_SCREW_NUT_WASHER	Fasteners Hydraulic Hand Pump
8	1	3/8 B x 3/8 F/F-750_1.5K	3/8 Hose & Fittings Assembly
9	1	6_pnl0-s	Cylinder Inlet Plug
10	1	CBR-2-CB-056-750-ASSY-LM-1.8K	Chassis & Hydraulic Lift Assy
11	2	DRIVE_WHEEL_MOUNT_ASSY_10_THK	Drive Wheel Mount
12	1	EMOVEFORK_080-40-950-2A-2K_450C	Fork & Carriage Assembly
13	2	FRONT-CASTOR-GUARD-60K	Castor Guards
14	1	Ergo_Handle_Assy_EML_1.8K	Controls & Handle Assembly
15	2	HPTCV-12-MOUNT-PLATE	Hydraulic Hand Pump Mount
16	2	U-BOLT	Controls & Handle Mounting
17	1	STRUT_L_V7	Left Strut
18	1	STRUT_R_V7	Right Strut
20	1	WEB_ASSY_L	Web Assembly
21	1	WEB_ASSY_R	Web Assembly
25	1	TRUNKING_GALV_100X100X850	Cable Trunking
26	2	SIDE_ARM_90X50X700X5THK_TOP	Detachable Side Arms

Appendix A – Hydraulic Oil Specification

MORPRESS AWG RANGE

High performance Hydraulic fluids

Morpress AWG hydraulic oils are premium quality anti-wear oils they meet or exceed the requirements of the leading manufacturers of hydraulic equipment and are available in a wide range of viscosities.

Morpress AWG have been developed for high pressure systems operating under moderate to severe conditions. They provide excellent protection against oxidation degradation, rust, corrosion, wear and possess superior foam control, water separation and rapid air release properties.

Morpress AWG hydraulic oils have been designed to be used in all types of hydraulic pumps and motors that require the use of anti-wear fluids. The appropriate viscosity grade will provide excellent service in plain and friction bearings and moderate service in gear reducers.

Features & Benefits

- Anti-wear properties
- Resistant to oxidation
- Formulated on high quality mineral oil
- Excellent thermal stability
- Good water separation
- Resistance to sludge formation
- Non corrosive to steel and copper alloys
- Good compatibility with elastomers and seals

Typical Data

Morpress AWG	22	32	37	46	68	100	150	
ISO Grade	22	32	37	46	68	100	150	
Viscosity @40oC	21.5	31.5	37.2	46.3	67.6	100.2	148.8	mm ² /s
Viscosity Index	98	98	98	98	98	98	98	min
Flashpoint COC	186	202	207	210	218	230	230	oC
Pourpoint	-21	-21	-21	-21	-21	-21	-21	oC (max)
Specific Gravity @20oC	0.87	0.87	0.87	0.87	0.88	0.88	0.88	

Morpress AWG hydraulic oils are blended to meet or exceed the following industry standards

Denison (HF-0 HF-1 HF-2)	ISO 11158 (HM Fluids)
Cincinnati Milocron P-68, P-69, P-70	U.S. Steel 127, 136
DIN51524, part 2 (HLP)	Eaton Vickers I-286-S, M-2950-S
Afnor NF E 48-603	Denison Filterability TP 02100

Safety Datasheet:

[MORPRESS RANGE ISO HYDR OIL SDS](#)

Appendix B – General Arrangement

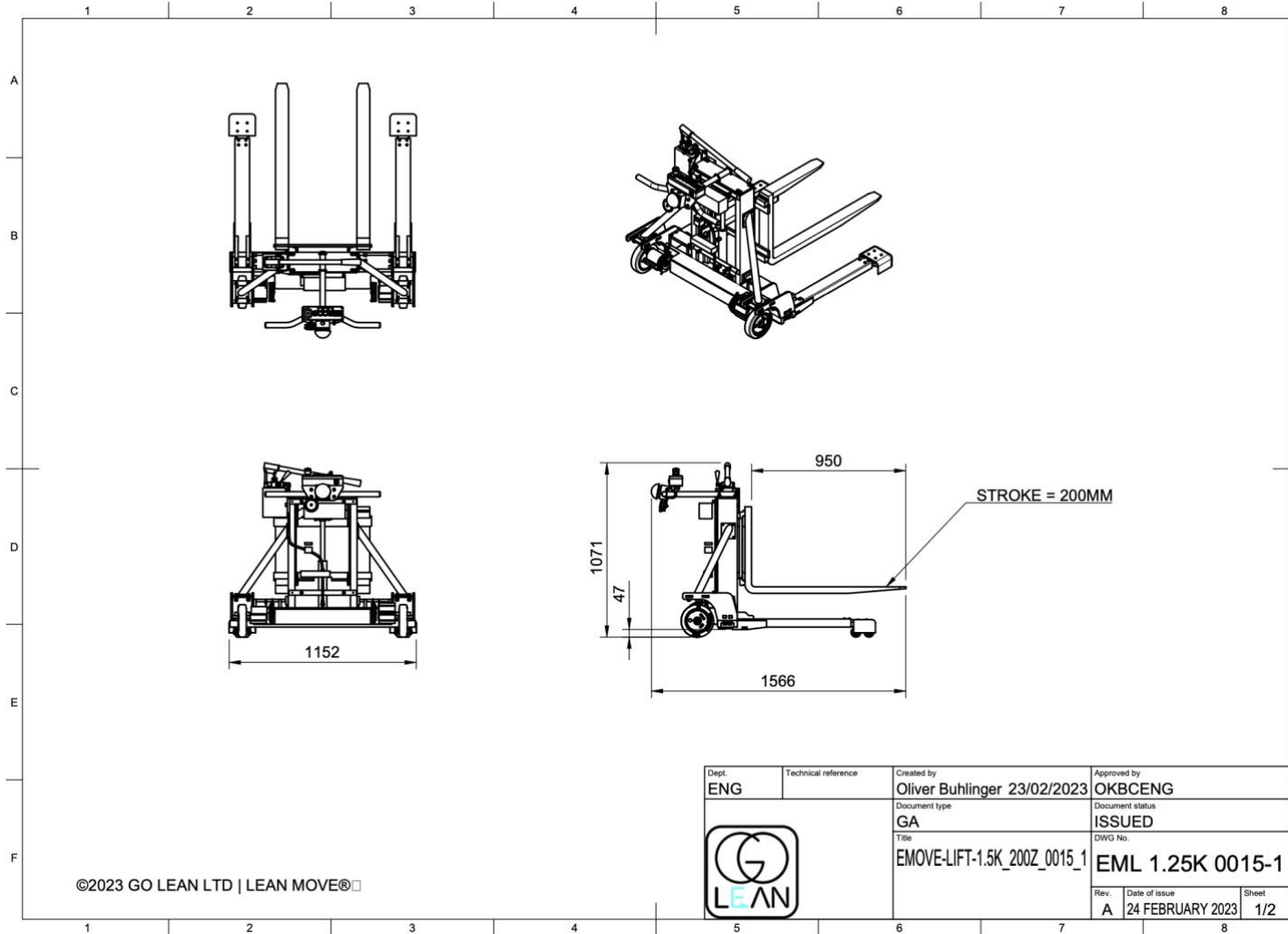



Glossary of Terms

Term	Meaning
SWL	Safe working load
CE	"Conformité Européenne" which means "European Conformity"
UKCA	UK Conformity Assessment
CoC	Certificate of Conformity
EML	Emovelift
SDS	Safety Datasheet